

PH-3515F Horizontal Optical Comparator

Mitutoyo



**Excellent, All-Purpose Horizontal-Beam
Profile Projector**

PH-3515F Profile Projector

Series 172

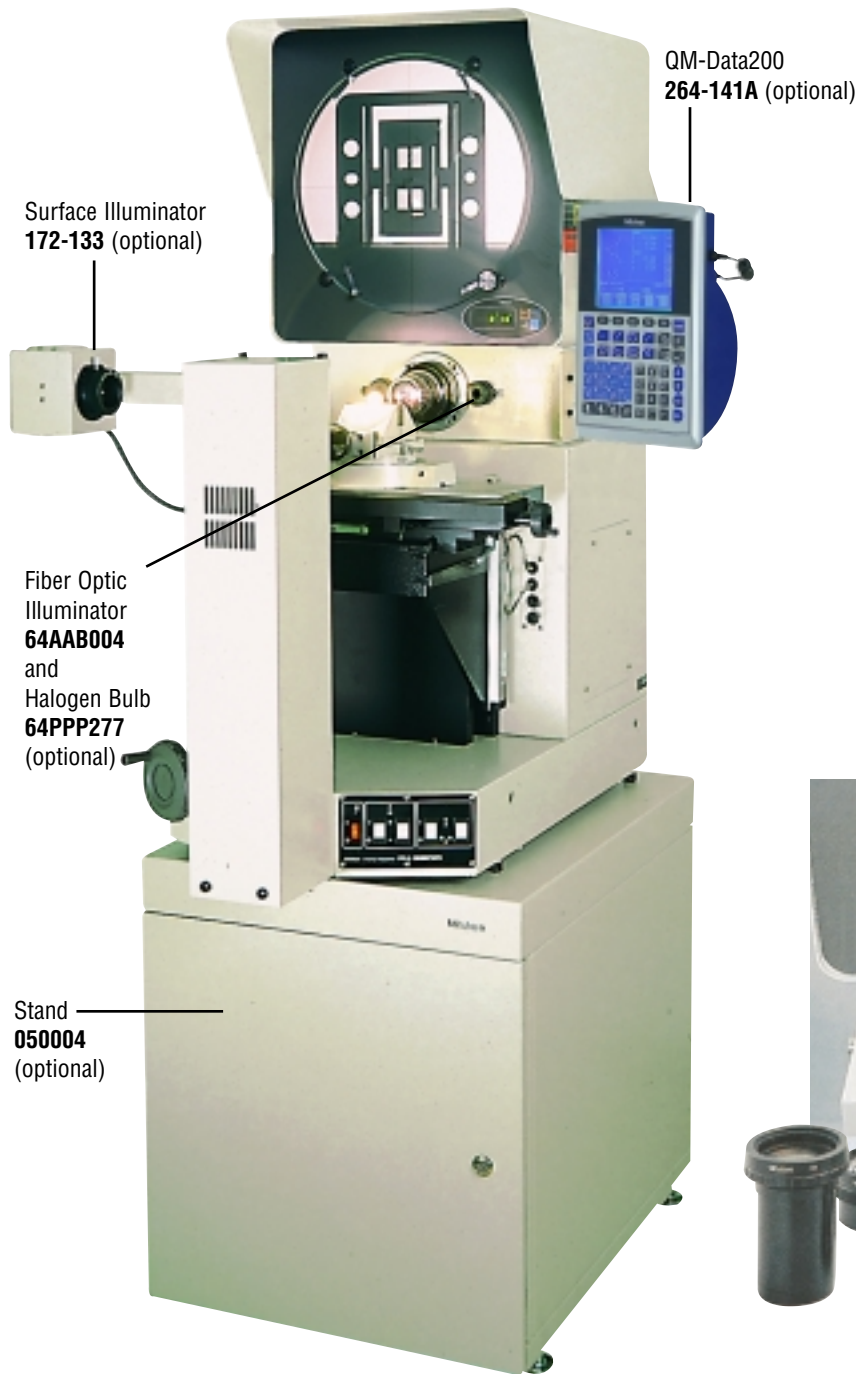

Features

- *Heavy-Duty, bench-top model with horizontal optical system.*
- *Erect image on Day-bright screen.*
- *14" (356mm) dia. protractor screen with crosshair line for easy alignment.*
- *Digital angle measurement to 1' or 0.01°.*
- *Floating-type workstage incorporates linear scales for fast, accurate measurement.*
- *Contour illumination with halogen bulb. Surface illumination with halogen bulb.*
- *Suitable for thread pitch measurements — free from blurred or distorted images when the workpiece is angled.*
- *Wide range of accessories for various applications.*

Projection Lenses

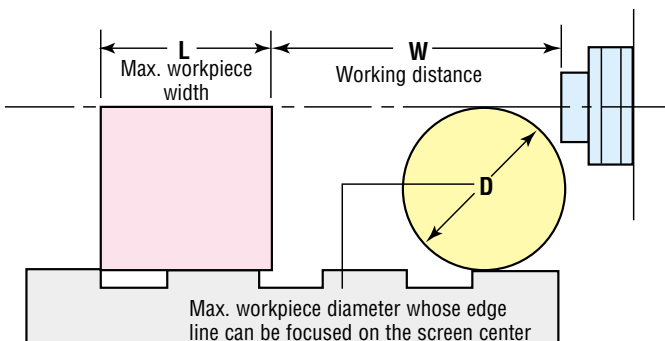

PH-3515F Unit: *inch*

Illumination	Contour					Surface				
	5X	10X	20X	50X	100X	5X	10X	20X	50X	100X
Magnification	5X	10X	20X	50X	100X	5X	10X	20X	50X	100X
View field dia.	2.80	1.40	.70	.28	.13	2.80	1.40	.70	.28	.13
W	6.30	3.66	1.57	.57	.37	2.52	1.61	1.57	.57	.37
L	6.89	9.25	9.25	3.15	4.29	6.89	9.25	9.25	3.15	4.29
D	6	6	4.57	1.20	.75	6	6	4.56	1.19	.75

System Diagram with Optional Accessories

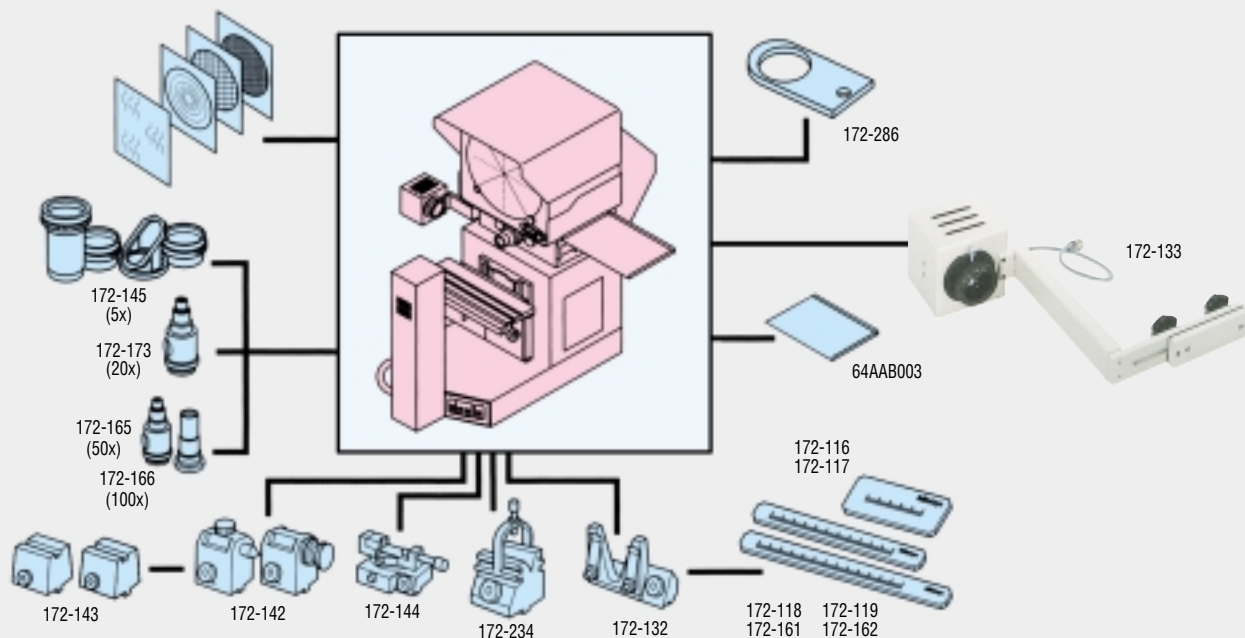

Specifications

Model	PH-3515F
Type	inch/mm
Order No.	172-848-1A
120VAC	
Resolution	.0001"/.00005"/0.001mm
Projection lens set	10X (172-184)
Magnification accuracy	±0.1% under contour illumination, ±0.15% under surface illumination
Protractor screen	
Effective DIA.	14" (356mm)
Screen material	Fine-grain ground glass
Reference line	Staggered and cross-hairs line
Display range	±370°
Resolution	1"/0.01° switchable
Functions	ABS/INC mode switch, zero-setting
Contour illumination	
Light source	Halogen bulb (24V, 150W)
Optical system	Telecentric
Functions	2-step brightness switching, cooling fan heat-absorbing filter, green filter (optional)
Surface illumination (optional accessory)	
Light source	Halogen bulb (24V, 150W)
Functions	Adjustable condenser lens (for all magnifications), cooling fan, heat-absorbing filter
Power supply	100/110/120/220/240V AC (switchable), 50/60Hz
Mass	330 lbs. (150kg)
Standard accessories	10X projection lens set, workstage, power cord, halogen bulb 24V 150W (2 pcs), machine cover (383228), user's manual

Workstage (Standard Accessories)

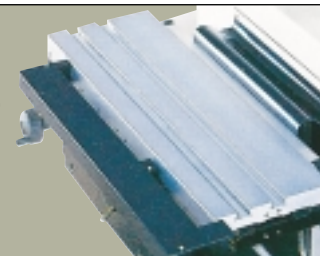

XY range	X-axis (horizontal travel): 10" (254mm) Y-axis (vertical travel): 6" (152mm)
Measuring unit	Linear scale for each axis
Stage size (W x D)	17.72" x 5.75" (450 x 146mm)
Swivel range	±10° (30' reading)
Max. workpiece load	99 lbs. (45kg)
Dovetail groove	Two (Pitch = 43mm)
Focusing travel	2" (50mm)

Dimensions

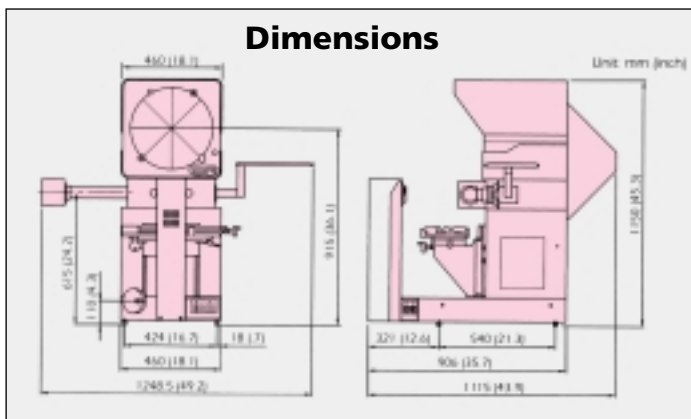

Optional Display Units



QM Data 200

QM-Data200

Order No.	264-141A (Arm-mount model)
Resolution	.00002"/.00005"/.0001" (0.0005mm/0.001mm)
Software	Standard geometric element Geometry combination pattern Memory: 1000 elements (max)
Dimension	7.87" (W) x 11.02" (H) x 3.54" (D)



Micropak 2RS

Micropak 2RS

Order No.	983-357A
Resolution	.00002"/.00005"/.0001" (0.0005mm/0.001mm)
Software	Standard geometric element
Dimension	11" (W) x 6.5" (H) x 5.75" (D)
Option	Edge sensor: 50AAD288 Mounting Plate 13.75": 016312

*Need Counter Tray **64AAB003**



KL Counter

KL Counter

Order No.	174-163A
Resolution	.0001"/.0005"/.001" (0.001mm/0.005mm/0.01mm)
Dimension	10.87" (W) x 6.97" (H) x 3.94" (D)

*Need Counter Tray **64AAB003**